



Waterproof Action Camera

Instruction Manual



Congratulations on your purchase of the Covert Action Camera. This 1080P full HD Covert Camera provides simple operation, allowing you to capture all those awesome moments you wish you had on camera. Whether it's fishing, mudding, hunting or any other extreme activity, this camera is durable, water proof and small. Record your videos hands free with a simple push of a button! We truly value your business and will strive to provide you top quality customer service should you ever need help with any of our products. Check out our other products on our website at:

www.covertscoutingcameras.com

Table of Contents

Button Function Diagram	1
Features	2
Insert/Ejecting Memory Card	3
About Leveling Sensor	3
How to Use the Leveling Sensor	3
Record	4
Playback on the Computer	5
Live Video Output	6
Playback on TV	6
Charging	7
Format	8
Setting Your Time/Date	8
Specifications	11
Precautions	12
Troubleshooting Tips	13
Covert Warranty Policy	15

Button Function Diagram

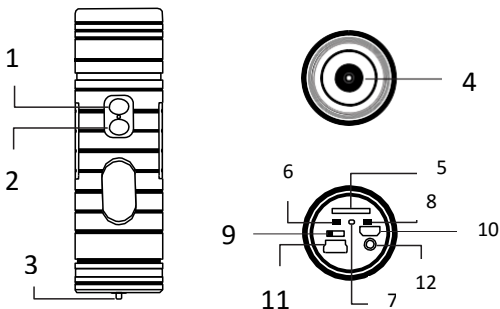

1. On/Off/Power Indicator
2. Record/Stop/Recording Indicator
3. Clip
4. Lens
5. Card Slow
6. MIC Switch Button
7. MIC Indicator
8. Reset Button
9. Resolution Switch
10. HDMI Output
- 11, USB Connection
12. A/V Output/MIC In Connection

Features

- 1080P HD digital recording with audio or 720P@60fps & WVGA@60fps
- 5 MP
- Low illumination recording
- H.264 compression, records approx 6 hours 1080P videos on a 32GB Micro SD card
- Rechargeable Li-ion Battery with up to 140 minutes recording time
- Built-in microphone, external microphone is included for higher quality sound
- Support recording while charging
- Overwrite recording
- Round metal casing, Shock resistant
- Water proof, up to 30 feet.
- Date/Time stamp on digital video (optional).
- Supports live video output
- HDMI output, high definition image playback on TV
- Leveling Sensor

Insert/Ejecting Memory Card

Insert your micro SD or micro SDHC card into the camera. Make sure the SD card is not full. Gently push the card into the slot until it locks in place. To eject the card, gently push the card to release.

About Leveling Sensor

When using on a rifle or shotgun, the cameras may be mounted under the gun barrel, thus the button is on top and difficult to operate. With the leveling sensor, you can make the videos stay level even when the buttons are on the bottom.

How to Use the Leveling Sensor

When you turn on the power, the camera will be in standby mode. Turn over the camera and make sure the buttons are on the bottom. (Opposite side down.) Then start recording again, and the video will stay level.

Record

1. Keep the micro SD card in card slot.
2. Select the video resolution you prefer on the back panel, and then close the rear cap.
3. Press and hold button one until vibrator shakes then release. Wait 2 seconds, two indicators turn on—one is red and two is green. The camera now is in “standby mode.”

Attention:

1. The camera will turn off automatically if the camera is idle for 5 minutes.
2. It will start to record automatically if set `AutoRecord = Y`,
3. Press button two shortly, the vibrator shakes; then the green indicator flashes. The camera is now recording.
4. Press button two again. When the green indicator stops flashing and vibrator shakes twice, the camera stops recording, thus saving video file automatically.
5. Press and hold button one in standby mode until vibrator shakes, the camera turns off.

Attention:

1. Keep the micro SD card in the slot and turn on the camera.
2. Unscrew the rear cap; insert the external microphone into the camera.
3. Press the MIC switch button (with the D mark) on the panel of the camera.
4. The MIC indicator (with the E mark) turns on. The voice recording will be via external MIC, so the internal MIC does not work at the same time.

Playback on the Computer:

1. Make sure the camera turns off. Keep the card in the camera and connect the camera to the computer by USB cable provided in the package.
2. It shows “found new hardware” on the computer. (Note: This can take up to 30 seconds.)
3. Open “Removable Disc” on the computer. You will see video files. Transfer all the videos to your computer first, and then play the videos. You can then copy or delete the videos from the SD card.
4. Safely remove the hardware, eject the disc and take out the USB cord from the computer.

Remarks:

1. This camera saves videos by MP4 format and can be played via Windows Media Player or Quicktime.
2. The Covert Rush Camera records full HD videos in large bitrates. If playback is not smooth, please try other players or high configuration computers.

Live Video Output:

1. Unscrew the rear cap and connect the camera to monitor/TV/display device with the RCA video cable provided.
2. Turn on the camera and the live video will output. Make sure the camera is installed well and the image is being recorded.
3. Take off the cable after use. Do not forget to screw the rear cap tightly.

Playback on TV:

1. Unscrew the rear cap; connect the camera and TV with the HDMI cable provided.
2. Select correct "HDMI" mode on TV, turn the camera onto standby. The video will then output real time.
3. Press and hold Button two for 2 seconds until the video file list displays on your TV.
4. Select the file by Button two, play or pause it

by pressing button one.

5. During play back, Press Button two and it will play the next file.

6. Press and hold Button two for 2 seconds. The camera will return to the video file list.

7. In the video file list interface, press Button two for 2 seconds, the camera will return to standby mode.

8. Then press and hold Button one for approximately 3 seconds, and the camera will turn off.

Charging:

1. Connect the camera to your PC/labtop/USB charger by using the USB cable provided.

2. Once connected, the red indicator on the camera will turn on then flash. The unit will then be charging. (You can also record while you charge your camera if you set AutoRecord=Y. (See below for directions.)

3. After around 3-4 hours when it stops flashing, the camera is fully charged.

4. Remove the camera from the power source.

Attention:

1. 5 minutes after fully charged, the camera will

automatically turn off all indicators if you do not remove it from the power source.

2. The camera will record while charging if set AutoRecord=Y. In order to keep your previous data on the card, please stop recording or take the card out.

Format:

In the standby mode if the internal microphone ON, press and hold the MIC switch button until the camera begins to vibrate then release the button. The camera will turn itself off after a long vibration. The formatting is now complete. Formatting will delete all data from the micro SD card. Please use this operation with caution.

Setting the Time/Date:

1. Create a new “.txt” file. Save it as “time.txt”
2. Input the correct date and time according to the following format.

Example: 2014/01/15 08:55:00

- 2014 is the year, 01 is the month, 15 is the day.
08 is the hour, 55 is the minute, 00 is the second.
3. Copy the text into micro SD card, stored under Removable Disc/My Computer.

4. Remove your camera from the computer. Restart your Covert Rush Camera and record. Your date and time are set up successfully.

Other Setup:

1. Insert a card, turn the camera on, and then turn the camera off. This will create the setup file on the card automatically.
2. Connect the camera to the computer by the USB cable.
3. Open the removable disc, find the file named "set.txt" in the card.

Timestamp=Y

AutoRecord=N

MaxRecordTime=30

Cycle Record=N

Set **TimeStamp**, **AutoRecord**, and **CycleRecord** by "Y" or "No". Set **MaxRecordTime** from 1-60 minutes.

Timestamp = Y	With date/time stamp on video records.
Timestamp = N	Without date/time stamp on video records.
MaxRecordTime	Video recording section, support 1 to 60 minutes. Standard is 30 minutes.
AutoRecord = Y	Auto mode, record when power on.
AutoRecord = N	Manual mode, press button to record when standby.
CycleRecord = Yes	Overwrite files in front and continue recording automatically when card is full.
CycleRecord = No	Stop recording then turn off when card is full.

Specifications

Image Sensor	1/2.5 inch CMOS
View Angle	60 degrees
Image Sensor Pixel	5.0 MP
Recording Resolution & Frame Rate	1920*1080(1080P)/30fps 1280*720(720P)/60fps 848*480(WVGA)/60fps
Video Format	MP4
Compression	H.264
Video File Size	1500KB/second while 1080P 800KB/second while 720P 500KB/second while WVGA
Video Recording Section	1 to 60 minutes
USB Interface	USB 2.0
Memory	No built-in flash, support micro SD card up to 32GB
Battery Capacity	1000mAh
Battery Working Time	140 minutes
Battery Charging Time	3-4 hours
Dimension	4.06*1.22*1.18 inches
Weight	.25 ounces

Precautions

1. Do not use the camera in extremely hot, cold, dusty or damp environments.
2. The Covert Action Camera is shock resistant, not shock proof. Try to avoid dropping it when possible.
3. The camera is waterproof up to 30 feet. Please make sure the O-rings are sealed and the front and rear caps are closed tightly to avoid any damage by the water.
4. Do not disconnect the camera from your PC when uploading or downloading footage, it may damage your camera or corrupt your files.
5. The camera required a micro SD card to work so please insert card before using.
6. The battery life varies according to the temperatures. A colder environment will drain the battery faster. Normal operating is around 140 minutes.
7. Please check and charge the camera when you do not use it for a long period of time.
8. Do not take the camera apart—this will break the tamper seal and void out warranty.

Troubleshooting Tips:

Q. It doesn't work, what do I do now?

A. Make sure your Action Camera has power and that there is a micro SD card in the slot. Also make sure the SD card is not full. If you are still having issues, try another card.

Q. The camera will not charge.

A. Use another USB cable or AC adapter. Reset the camera, and format your card in the computer.

Q. How do I know if the card is full?

A. The green light flashes quickly, the camera will shake six times, and then turn off automatically. When this happens, the SD card is full.

Q. How do I know if the battery is low?

A. The red light flashes quickly, the camera will shake four times then automatically turn off. Charge your Action Camera because there isn't enough power for it to function properly.

Q. The camera is really hot when I use it, is that

normal?

A. The camera is made from aluminum alloy with a waterproof sealing structure. It is normal for the camera to run a hot. Please do not worry.

Q. Why are the video and audio out of sync on the PC?

A. Copy the video files to your computer, then try again. Make sure that your player is updated on your PC or try to play the video with a VLC Media player.

If you are still having problems with your Covert Action Camera, after checking the above potential causes and solutions please either check out our website at **www.covertscoutingcameras.com** or contact customer service at 877-462-1799 or e-mail us at **support@dlccovert.com**

IMPORTANT NOTE: Contact Covert Support for troubleshooting prior to contacting the retail store from which you purchased the product. We will be happy to take care of you!

Covert Scouting Cameras Warranty:

Covert Scouting Cameras warrants this product for a period of 1 year from the date of purchase. This warranty only covers manufacturer's defects and does not cover damage caused by misuse or abuse of the product. This warranty includes one year repair or replacement service on product from date of purchase. If you have problems with this product, please do not contact the store you purchased it from. Contact Covert Scouting Cameras Customer service toll free at 877-462-1799 or e-mail us at support@dlccovert.com. Proof of purchase will be required for replacement.

Covert Warranty Policy and Procedure:

To receive repair or replacement by Covert Scouting Cameras one year warranty, we ask you to do the following:

-All returns must have a Return Authorization (RA#) prior to sending in the camera.

1. E-mail or call our customer service department.

-support@dlccovert.com

-toll free: 877-462-1799

Please explain to the technician what issues you are having with your camera.

2. If you are asked to return your camera to Covert Scouting Cameras, you will be responsible for the cost of shipping to Covert Scouting Cameras. In return, Covert will provide fast and exceptional service as well as incur the cost of shipping back to you. (Only within the Continental United States.)
3. Please include the following information when sending in your camera.
 - RA# on outside of package
 - Return address
 - Telephone and Email address
 - Brief description of the problem
 - Copy of proof of purchase
4. Please make sure all the accessories are removed (i.e. SD Cards, batteries, solar panels, SIM cards, straps, ETC.) before shipping. All accessories received by Covert Scouting Cameras will NOT be returned.
5. This warranty only covers manufactures' defects and does not cover damaged caused by misuse or abuse of the product.

Covert International Warranty Policy and Procedure:

1. Outside the US, service is the available through the distributor/reseller of purchase.
2. All returns must have an RA# provided by Covert. Copy of Proof of Purchase is required for all returns.
3. Covert is not responsible for lost or damaged products incurred during the shipping process.
4. Insurance for returns is at the discretion of the customer. Additional charges apply for return shipping.

In the maintenance of the product, Covert Scouting Cameras may use new or equivalent, to new parts, assemblies or products for equal or improved quality. All defective parts, assemblies, and products became the property of Covert. Return and claims will be handled according to the current Covert Scouting Cameras, Inc. procedure.

These warranties shall not apply to any defect, failure or damage caused by improper use or improper or inadequate maintenance and care. Covert shall not be obligated under these warranties:

- a. To repair damage resulting from attempts by personnel other than Covert representatives to install, repair or service the product unless directed by a Covert representative.
- b. To repair damage, malfunction or degradation of performance resulting from improper use or connection to incompatible equipment or memory.
- c. To repair damage, malfunction, or degradation of performance caused by the use of non-Covert supplies or consumables or the use of Covert supplies not specified for use with this product.
- d. To repair an item that has been modified or integrated with other products when the effect of such modification or integration increases the time or difficulty of servicing the product or degrades performance or reliability.
- e. To perform user maintenance or cleaning or to repair damage, malfunction.
- f. To repair damage, malfunction or degradation of performance resulting from use of the product in an environment not meeting the operating

specifications set forth in the user manual.

- g. To repair damage, malfunction or degradation of performance resulting from failure to properly prepare and transport the product as prescribed in published product materials
- h. Failure to register the product warranty within 10 days of purchase.
- i. To replace items that have been refilled, are used up, abused, misused, or tampered with in any way.
- j. To install replacement items that are not considered customer replaceable.
- k. To support software not supplied by Covert
- l. To provide software or firmware updates or upgrades.

Any service identified in the above list and provided by Covert at the Customer's request shall be invoiced to the customer, at Covert's then current rates for parts, labor and shipping.

THE ABOVE WARRANTIES ARE GIVEN BY COVERT WITH RESPECT TO THIS PRODUCT AND ITS RELATED ITEMS IN LIEU OF ANY OTHER WARRANTIES, EXPRESS OR IMPLIED. COVERT AND

ITS VENDORS DISCLAIM ANY IMPLIED WARRANTIES OF MERCHANTABILITY OR FITNESS FOR A PARTICULAR PURPOSE OR ANY SIMILAR STANDARD IMPOSED BY APPLICABLE LEGISLATION. COVERTS RESPONSIBILITY TO REPAIR, REPLACE, FOR DEFECTIVE PRODUCTS AND RELATED ITEMS IS SOLE AND EXCLUSIVE REMEDY PROVIDED TO THE CUSTOMER FOR BREACH OF THESE WARRANTIES.

Some states, provinces, and countries do not allow the exclusion or limitation of incidental or consequential damages or exclusions or limitation on the duration of implied warranties or conditions, so the above limitations or exclusions may not apply to you. This warranty gives you specific legal rights, and you may also have other rights that vary by state, province, or country.

TO THE EXTENT ALLOWED BY LOCAL LAW, EXCEPT FOR THE OBLIGATIONS SPECIFICALLY SET FORTH IN THIS WARRANTY STATEMENT, IN NO EVENT SHALL COVERT AND ITS VENDORS BE LIABLE FOR ANY INDIRECT, SPECIAL, INCIDENTAL OR CONSEQUENTIAL DAMAGES (INCLUDING LOSS OF PROFITS) WHETHER BASED ON CONTRACT, TORT, OR ANY OTHER LEGAL THEORY AND IRRESPECTIVE OF WHETHER COVERT OR THE VENDOR HAS

ADVANCE NOTICE OF THE POSSIBILITY OF SUCH DAMAGES.

